

200W, 976nm, Fiber-Coupled, Multi-Bar Module Based on Conduction-Cooled, Tailored Bars

Features

- Conduction-cooled diode laser bars inside
- Single wavelength
- High coupling efficiency

Optional Accessories

- Integrated power meter
- Integrated NTC temperature sensor



Device Specification

Optical Parameters ¹	Units	
Center Wavelength	nm	976 ³
Wavelength Tolerance	nm	±3
Output Power ¹	W	200
Spectral Width (FWHM)	nm	<5
Slope Efficiency	W/A	>6.0

Fiber Parameters		
Fiber Core Diameter	µm	200
Numerical Aperture	NA	0.22
Fiber Connector		Optoskand SMA0.5Q

Electrical Parameters ¹		
Power Conversion Efficiency	%	>45
Threshold Current (I _{TH})	A	3
Operating Current (I _{OP})	A	<40
Operating Voltage (U _{OP})	V	<11.5

Thermal Parameters ⁴		
Operating Temperature ^{2, 3}	°C	+20 to +25
Storage Temperature	°C	+5 to +60
Coolant Flow Rate	l/h	>150
Water Temperature	°C	+20 to +25
Purity	µm	Tap Water

¹Data at 25°C cold water temperature, unless otherwise stated

²Reduced lifetime if used above nominal operating conditions

³Additional information available upon request

⁴A non-condensing environment is required for storage and operation below the ambient dew point

200W, 976nm, Fiber-Coupled, Multi-Bar Module Based on Conduction-Cooled, Tailored Bars

Package Dimension with Water Manifold

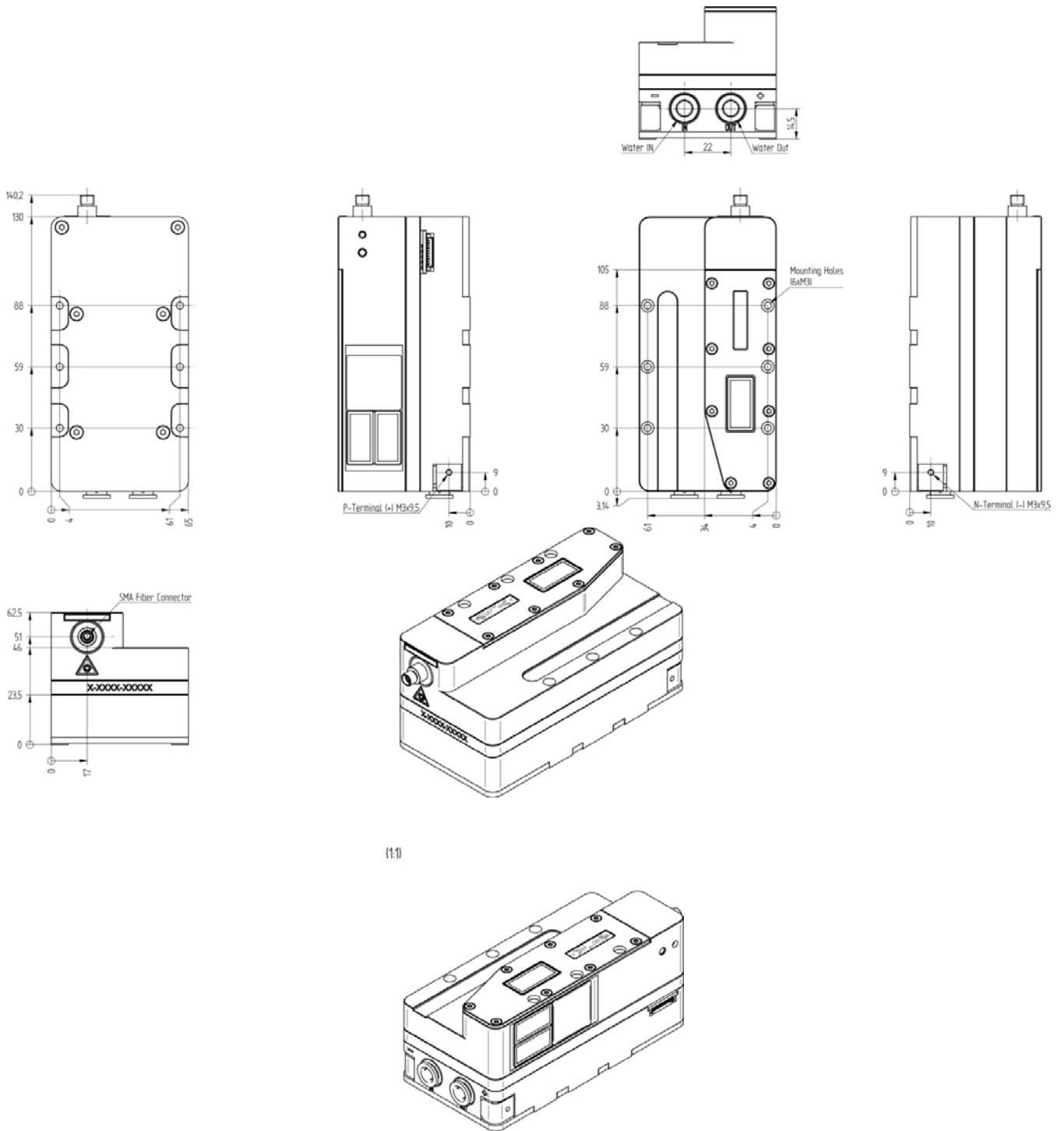

(1:1)

200W, 976nm, Fiber-Coupled, Multi-Bar Module Based on Conduction-Cooled, Tailored Bars

Package Dimension without Water Manifold

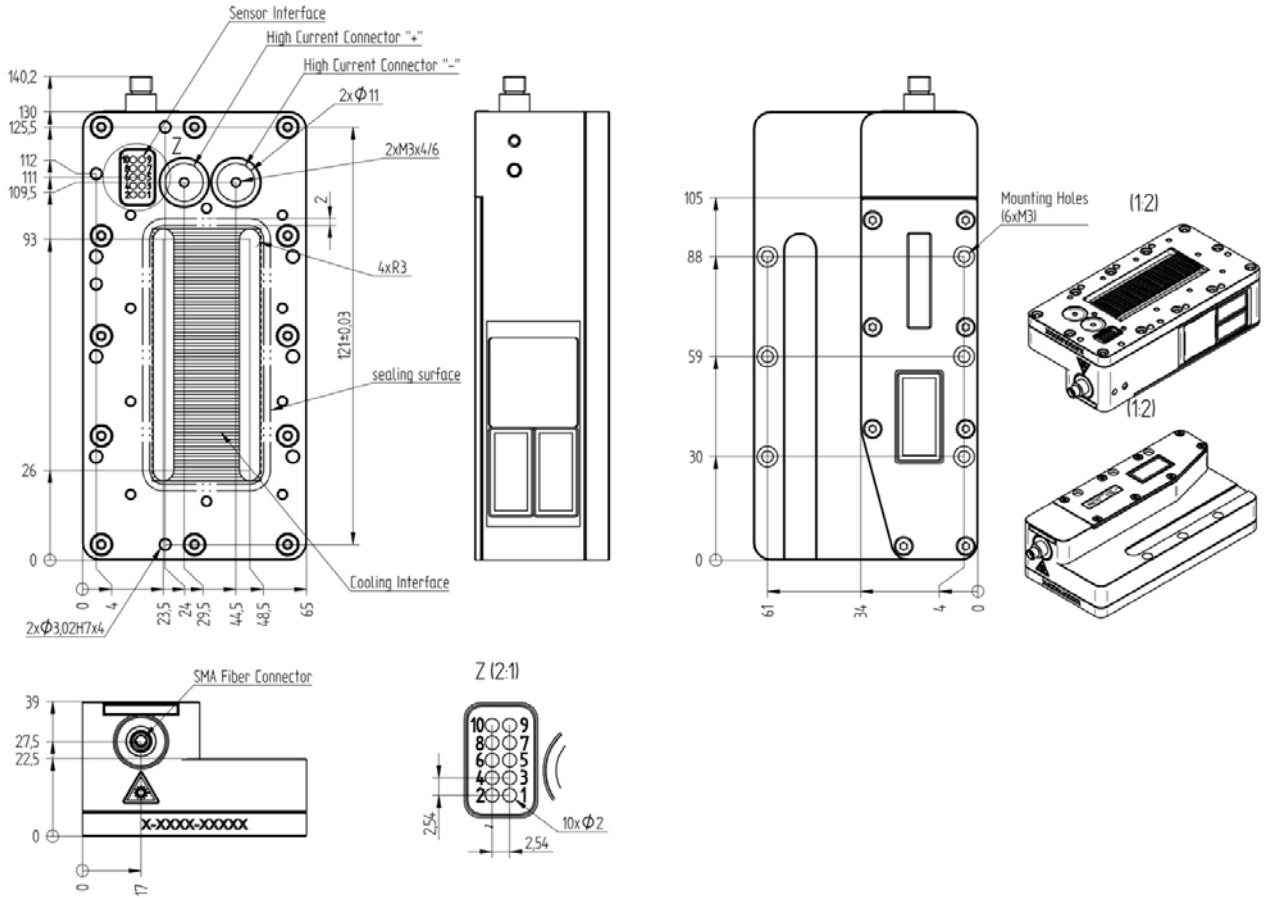

© 2012 DILAS. All rights reserved. DILAS reserves the right to change products specifications without notice. For handling precautions, please reference the general handling instruction manual.

For complete details, please contact your local DILAS sales representative or visit our website at www.DILAS.com.

Europe
DILAS Diodelaser GmbH
Galileo-Galilei-Straße 10
55129 Mainz
Germany
Phone: +49 (0)6131 9226 0
Fax: +49 (0)6131 9226 257
Email: sales@DILAS.de

North America
DILAS Diode Laser, Inc.
9070 South Rita Road
Suite 1500
Tucson, AZ 85747
Phone: +1 (520) 232-3480
Fax: +1 (520) 232-3499
Email: sales@DILAS-INC.com

China & Taiwan
DILAS Diodelaser GmbH
China Sales Office
Room 206, Sunplus Technology, Bldg. 2
No. 1077 Zu Chongzhi Road
Hi-Tech Park, Shanghai 201203,
P.R. China
Phone: +86 (0) 21-6855-2216
Fax: +86 (0) 21-5027-3793
Email: sales@dilas-china.com.cn