

400µm Conduction-Cooled Single Bar Fiber-Coupled Module Series (Unpolarized)

Features

- Truly unpolarized with a degree of polarization at <0.1
- High coupling efficiency
- High brightness
- Sealed housing
- Standard fiber coupling (HP-SMA) for 400µm NA 0.22



Device Specification

Optical ¹	Units	808	808	880	915	940	980
Center Wavelength Range ³	nm	808	808	880	915	940	980
Center Wavelength Tolerance	nm	±3	±3	±3	±3	±3	±3
Output Power ²	W	30	40	30	30	30	30
Spectral Width (FWHM)	nm	4	4	5	5	5	5
Slope Efficiency	W/A	≥0.7	≥0.7	≥0.7	≥0.7	≥0.7	≥0.7
Wavelength Temp. Coefficient	nm/°C	~0.28	~0.28	~0.30	0.31	0.34	~0.38
Degree of Polarization					<0.1		

Fiber Parameters

Numerical Aperture	NA	0.22
Fiber Core Diameter	µm	400
Fiber Connector		HP-SMA 905 with Free Standing Fiber Tips

Electrical Parameters¹

Power Conversion Efficiency	%	≥35	≥35	≥35	≥35	≥35	≥35
Threshold Current (I _{TH})	A	≤8.5	≤8.5	≤10	≤8.5	≤10	≤13
Operating Current (I _{OP})	A	45	57	45	48	50	50
Operating Voltage (V _{OP})	V	<1.9	<1.9	<1.9	<1.9	<1.9	<1.9

Thermal Parameters

Operating Temperature ^{3, 4}	°C	+20 to +30	+20 to +30
Storage Temperature ⁴	°C	0 to +55	0 to +55
Recommended Heatsink Capacity	W	≥70	≥90

¹Data at 25°C cold plate temperature, unless otherwise stated.

²Reduced lifetime if used above nominal operating conditions.

³Others available upon request.

⁴A non-condensing environment is required for storage and operation below the ambient dew point.

400µm Conduction-Cooled Single Bar Fiber-Coupled Module Series (Unpolarized)

Package Dimension

Module M1F-SS2.1

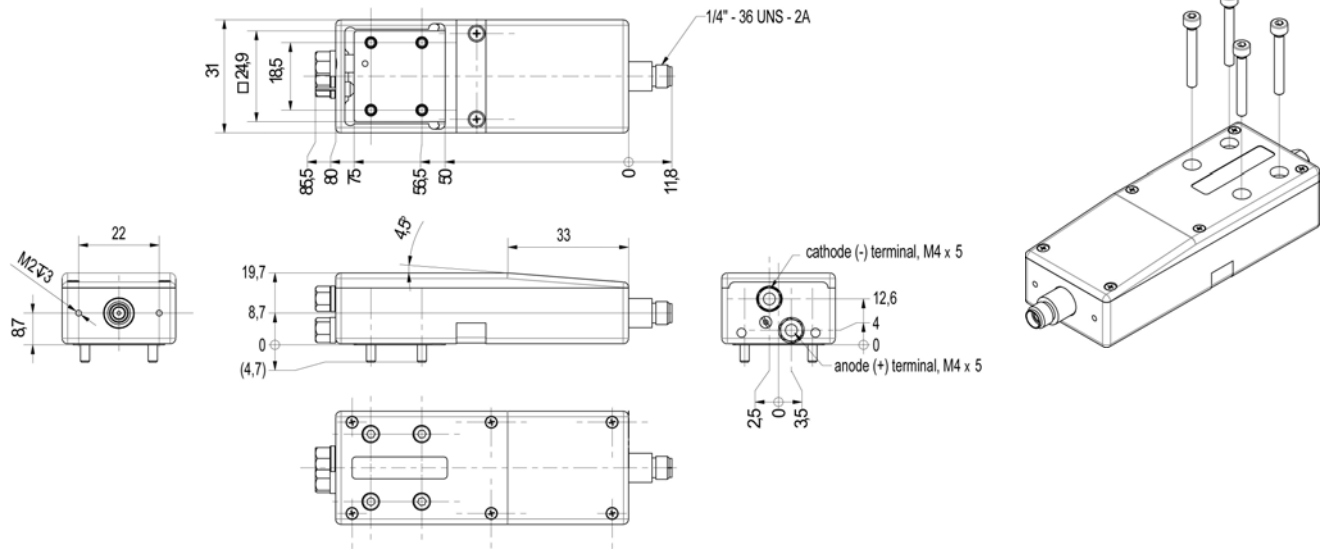

DILAS products specifications are subject to change without notice. For handling precautions, please reference the general handling instruction manual.

For complete details, please contact your local DILAS sales representative or visit our website at www.DILAS.com.

DILAS Diodenlaser GmbH
Galileo-Galilei-Straße 10
55129 Mainz
Germany
Phone: +49 (6131) 9226 0
Fax: +49 (6131) 9226 257
Email: Sales@DILAS.de
www.DILAS.com

DILAS Diode Laser, Inc.
9070 South Rita Road
Suite 1500
Tucson, AZ 85747
Phone: (520) 232-3484
Fax: (520) 232-3499
Email: Sales@DILAS-Inc.com
www.DILAS.com