

## Features

Easy-to-integrate system consists of a compact 19" (11HU including water-air-chiller), rack-mountable chassis, metal-armored fiber and imaging optics with protection glass. Can be combined with DILAS' processing heads offering camera and pyrometer options, and allowing the closed-loop operation of the system in pre-defined temperature ranges for quality relevant applications in medical device manufacturing and automotive.

Available with an optional fiber-input galvo scanner featuring a field of operation in which the laser spot can be freely addressed.



## Device Specification

Optical		
	Units	
Optical Output Power	W	200
Stability Over 24-hour (Cooling-Water $\Delta T = \pm 1K$ )	%	$\pm 2$
Wavelength <sup>1</sup>	nm	808/980 <sup>1</sup>
Wavelength Tolerance <sup>1</sup>	nm	$\pm 10^1$
Pilot Laser		
Wavelength	nm	650
Output Power	mW	<1
Fiber Parameters		
Fiber Connector Type		QBH (Water-Cooled)
Fiber Length <sup>1</sup>	m	5
Numerical Aperture	NA	0.2
Fiber Core Diameter	µm	200
Electrical Parameters		
Operating Voltage	V	200-240 Single Phase
Frequency	Hz	50/60
Power Consumption	kVA	1.4
Overall Efficiency	%	>12
Max. Rep Rate	Hz	500
Min. Pulse Width	µs	200
Min. Rise/Fall-Time	µs	150
Thermal Parameters		
Temperature Ambient in Operation (100% duty cycle)	°C	15 to 40 (Non-Condensing)
Storage Temperature	°C	5 to 50
Mechanical		
Dimension (Including Water/Air-Chiller) [w x h x d]	mm <sup>3</sup>	483 x 487 x 630
Weight (Including Water/Air-Chiller)	kg	65
Noise Emission	dB(A)	<70

## Package Includes

<sup>1</sup>COMPACT Laser Unit: 5m length<sup>1</sup>, water-air chiller, 2 warning lights and focusing unit PHFQ0 (f= 100mm). Consult the COMPACT Series Operating Instruction Manual for additional information.

<sup>1</sup>Consult DILAS Industrial Laser Systems for other available options.

## Package Dimension

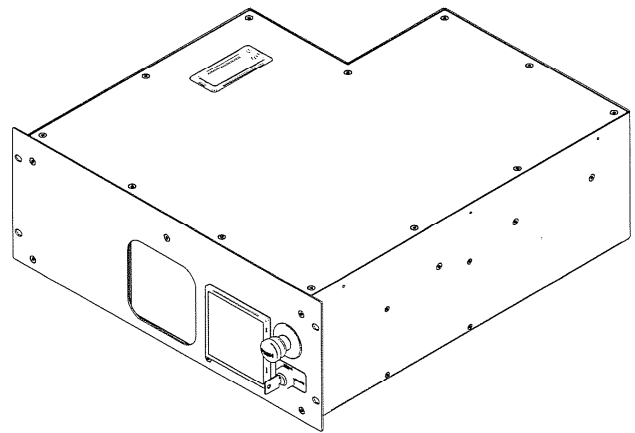
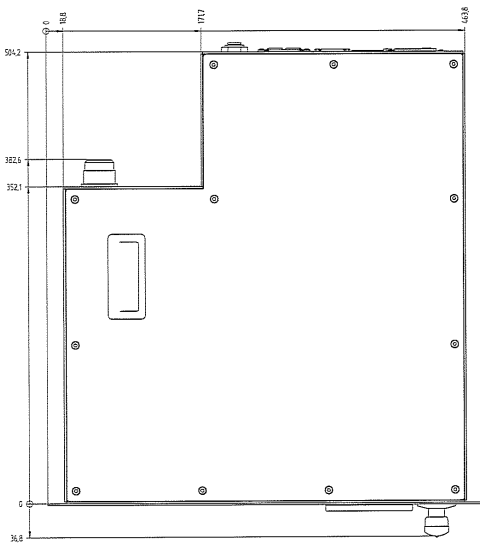
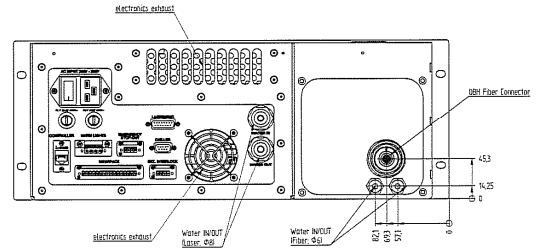
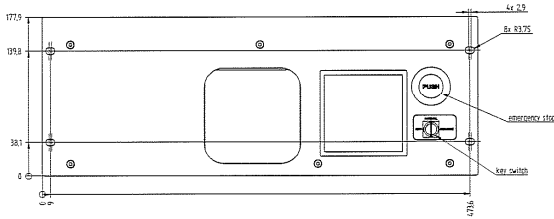

### U.S. CFR Regulation

The manufacturer and subsequent sale of laser equipment is under the guidelines governed by the U.S. Center for Devices and Radiological Health (CDRH). In accordance to those guidelines, specifically Subchapter J of the Radiation Standards, 21 CFR, the diode laser is registered as a CLASS 4 laser product.

### European Commission

In accordance to EN 60825, Safety of Laser Products, the diode laser is registered as a CLASS 4 laser product.

Products specifications are subject to change without notice. For handling precautions, please reference the general handling instruction manual. For additional information, please contact your local sales representative or visit our website at [www.dilas-ils.com](http://www.dilas-ils.com).

**DILAS Industrial Laser Systems**  
 a division of DILAS Diodenlaser GmbH  
 Galileo-Galilei-Straße 10  
 55129 Mainz  
 Germany

Phone: +49 (6131) 9226 400  
 Fax: +49 (6131) 9226 444  
 Email: [sales@dilas-ils.com](mailto:sales@dilas-ils.com)  
[www.DILAS-ILS.com](http://www.DILAS-ILS.com)

## Water-Air Chiller RK/W 800L

### Features

- High cooling capacity
- Small size cabinet
- Easy to integrate into standard industrial mounting racks
- Easy serviceable spare parts access



### Device Specification

Electrical Parameters		Units	
Operating Voltage		V	200-240 Single Phase
Frequency		Hz	50/60
Current Consumption	in Operation	A	3.9
	max.	A	6
Fuse	max.	A	10
Cooling Capacity		W	800
Heat Exchanger			V2A

Pump (NPY 50/60Hz)			
Number of Pumps			1
Pump Capacity	$Q_{max}$	l/min	12
Pump Height	$H_{max}$	m	50
Rated Current for Pump		A	1.3

Other			
Water Tank Volume		l	8
Connectors for Supply/Return Line		"	3/8
Heating			./.
Temperature Controller			./.

Mechanical			
Dimensions		mm	483 x 311 x 630
Weight	Empty	kg	~ 33
	with Water	kg	~ 41
Noise Emission		dB (A)	<57

(A-weighted equivalent continuous sound level)

### Water-Air Chiller RK/W 800L<sup>1</sup>

<sup>1</sup>Only use Water-Air Chiller RK/W 800L with the COMPACT (Liquid-Cooled) Series

## Package Dimension

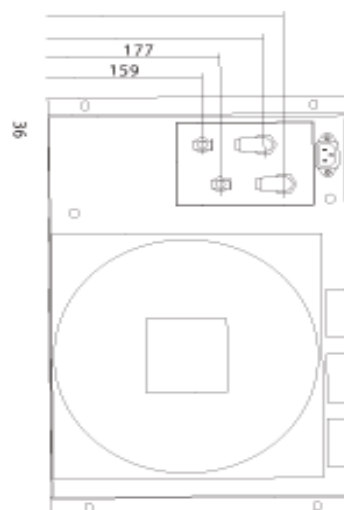
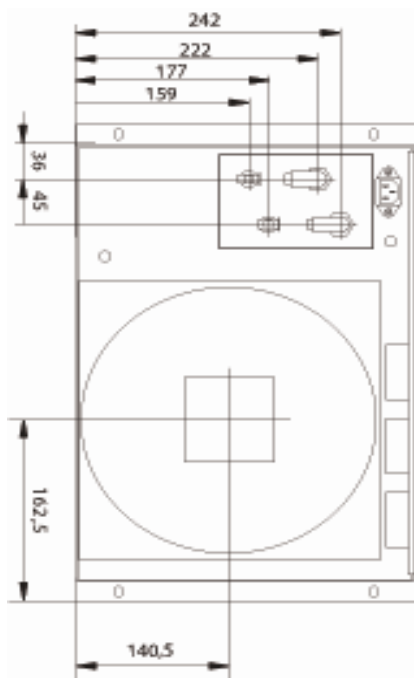
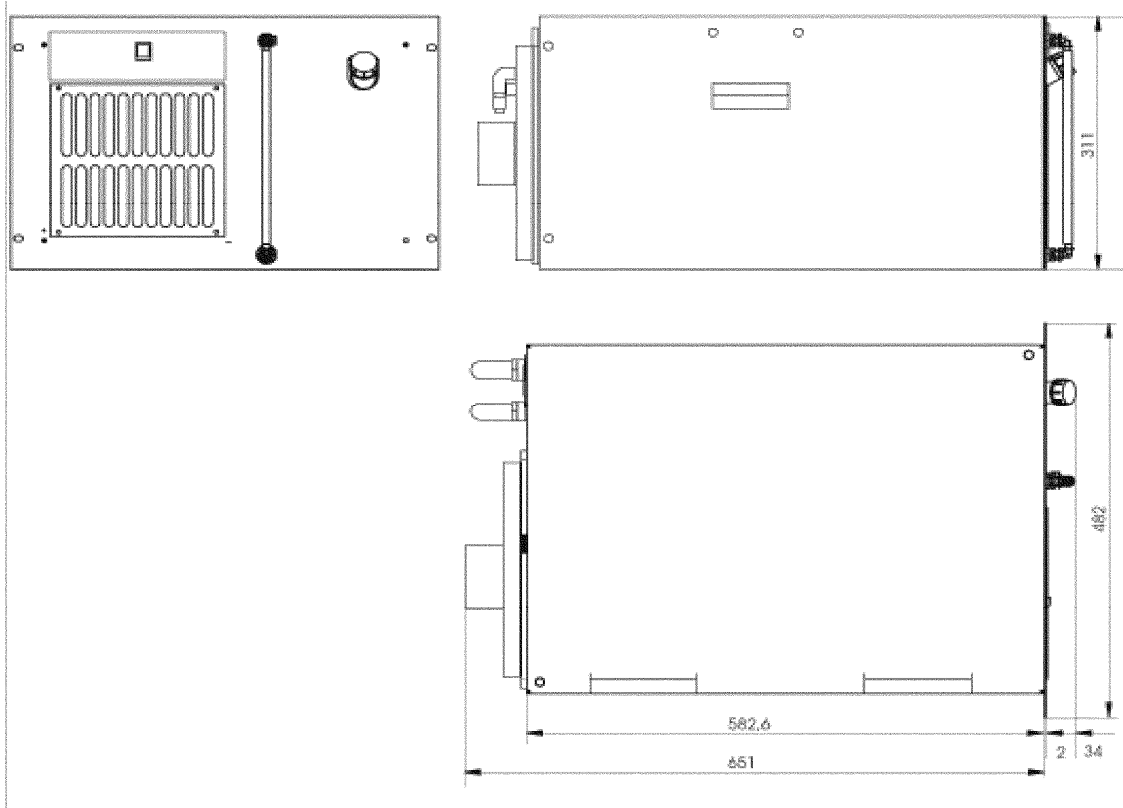

### U.S. CFR Regulation

The manufacturer and subsequent sale of laser equipment is under the guidelines governed by the U.S. Center for Devices and Radiological Health (CDRH). In accordance to those guidelines, specifically Subchapter J of the Radiation Standards, 21 CFR, the diode laser is registered as a CLASS 4 laser product.

### European Commission

In accordance to EN 60825, Safety of Laser Products, the diode laser is registered as a CLASS 4 laser product.

Products specifications are subject to change without notice. For handling precautions, please reference the general handling instruction manual. For additional information, please contact your local sales representative or visit our website at [www.dilas-ils.com](http://www.dilas-ils.com).

### DILAS Industrial Laser Systems

a division of DILAS Diodenlaser GmbH  
Galileo-Galilei-Straße 10  
55129 Mainz  
Germany

Phone: +49 (6131) 9226 400  
Fax: +49 (6131) 9226 444  
Email: [sales@dilas-ils.com](mailto:sales@dilas-ils.com)  
[www.DILAS-ILS.com](http://www.DILAS-ILS.com)

**Features**

- Water cooling
- Integrated fiber breakage control
- High power
- Fiber breakage control



**Device Specification**

Parameter	Units	
Connector Type		QBH on Both Sides.
Outer Diameter <sup>(Largest Diameter at Connector)</sup>	mm	50
Connector Diameter	mm	19
Fiber Length <sup>1</sup>	m	5
Numerical Aperture	NA	0.2
Core Diameter	µm	200
Long Term Bending Radius	mm	min. 300
Short Term Bending Radius	mm	min. 200
Flow Rate	l/h	90-115 max. 1 Bar Return Water Pressure
Cooling Water Temperature	°C	20°-25°

<sup>1</sup>Others on request.

**Torsion of more than 90° per meter has to be avoided.**

**Dimensions**

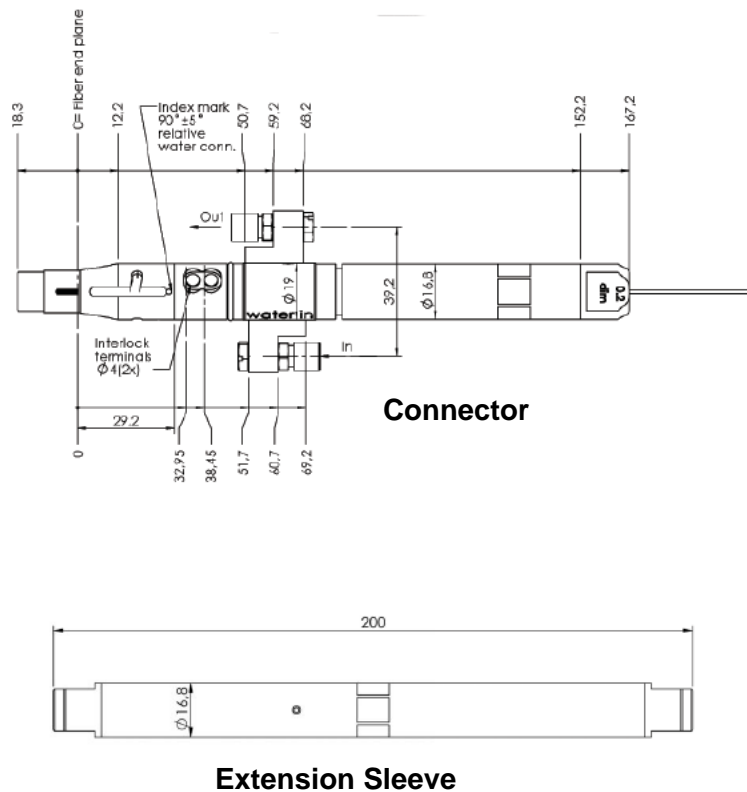

**Connector**

**Extension Sleeve**



**U.S. CFR Regulation**

The manufacturer and subsequent sale of laser equipment is under the guidelines governed by the U.S. Center for Devices and Radiological Health (CDRH). In accordance to those guidelines, specifically Subchapter J of the Radiation Standards, 21 CFR, the diode laser is registered as a CLASS 4 laser product.

**European Commission**

In accordance to EN 60825, Safety of Laser Products, the diode laser is registered as a CLASS 4 laser product.

Products specifications are subject to change without notice. For handling precautions, please reference the general handling instruction manual. For additional information, please contact your local sales representative or visit our website at [www.dilas-ils.com](http://www.dilas-ils.com).

**DILAS Industrial Laser Systems**

a division of DILAS Diodenlaser GmbH  
Galileo-Galilei-Straße 10  
55129 Mainz  
Germany

Phone: +49 (6131) 9226 400  
Fax: +49 (6131) 9226 444  
Email: [sales@dilas-ils.com](mailto:sales@dilas-ils.com)  
[www.DILAS-ILS.com](http://www.DILAS-ILS.com)

# Processing Head (PHFO) COMPACT Series Diode Laser System

## Features

This processing head with  $f=100\text{mm}$  (standard focal length)<sup>1</sup> is intended to be used with Compact Series along with an RQB or QBH fiber coupling. The processing head is connected to the diode laser using a fiber connector with RQB/QBH.

Having a compact housing this processing head can easily be integrated into the laser process.

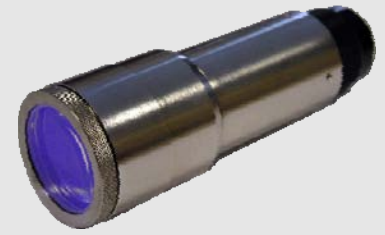

Optical		Standard		Optional	
Connector		RQB or QBH	RQB or QBH	RQB or QBH	RQB or QBH
Numerical Aperture	NA	0.22	0.22	0.22	0.22
Focal Length	mm	100	60	50 <sup>2</sup>	38 <sup>2</sup>
Working Distance (Stand Off)	mm	95	54	38	25
Output Aperture	mm	40	40	40	40

Weight					
Weight	kg	0.66	0.66	0.66	0.66

Fiber	$\mu\text{m}$	400	400	400	400
Focal Size <sup>1</sup>	mm	0.6 $\pm$ 0.05	0.4 $\pm$ 0.05	0.3 $\pm$ 0.05	0.25 $\pm$ 0.05

<sup>1</sup>Focal dimensions of diode lasers can deviate in practice depending on measuring method by  $\pm 10\%$ .

<sup>2</sup>With additional meniscus lens adapter.

<sup>3</sup>For standard focal length  $f=100$ .

Package Dimensions <sup>3</sup>		
Length	mm	144.2
Diameter	$\varnothing$	48

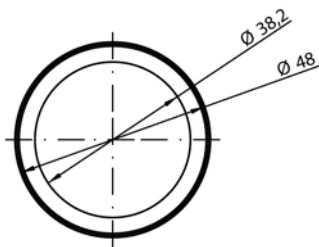

Spot size, see table above

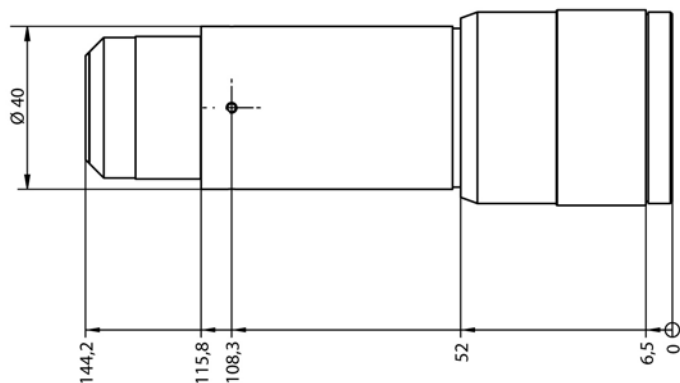

### U.S. CFR Regulation

The manufacturer and subsequent sale of laser equipment is under the guidelines governed by the U.S. Center for Devices and Radiological Health (CDRH). In accordance to those guidelines, specifically Subchapter J of the Radiation Standards, 21 CFR, the diode laser is registered as a CLASS 4 laser product.

### European Commission

In accordance to EN 60825, Safety of Laser Products, the diode laser is registered as a CLASS 4 laser product.

Products specifications are subject to change without notice. For handling precautions, please reference the general handling instruction manual. For additional information, please contact your local sales representative or visit our website at [www.dilas-ils.com](http://www.dilas-ils.com).

### DILAS Industrial Laser Systems

a division of DILAS Diodenlaser GmbH  
Galileo-Galilei-Straße 10  
55129 Mainz  
Germany

Phone: +49 (6131) 9226 400  
Fax: +49 (6131) 9226 444  
Email: [sales@dilas-ils.com](mailto:sales@dilas-ils.com)  
[www.DILAS-ILS.com](http://www.DILAS-ILS.com)