

Processing Head (PHFx9-CS) COMPACT Series Diode Laser System

Features

This processing head with $f=100\text{mm}$ (standard focal length)¹ is intended to be used with COMPACT Series. The processing head is connected to the diode laser using a SMA-905 fiber, NA 0.22 or QBH/RQB alternatively.

The integrated single color pyrometer is used for non-contact measuring of the work piece temperature. It is aligned in the optical path of the laser beam and has an internal digitizing unit which communicates with the PCI-card of the pyrometer PC. An advanced software package allows controlling the laser in closed loop. The pyrometer is a helpful tool to optimize processes and for their documentation. The laser head is also equipped with an integrated on-axis CCD camera for easy processing. The video signal can be displayed on any monitor with BNC connector.

By having a compact housing this processing head can easily be integrated into the laser process.



Device Specification

Optical	Units	Standard			Optional		
Connector					SMA-905 or QBH		
Numerical Aperture	NA				0.22		
Focal Length	mm	100 ¹	300	200	150	60	
Working Distance (Stand Off) ¹	mm	95	290	197.5	145	54	
Output Aperture	mm	40	40	40	40	40	
Fiber							
Fiber Core Diameter ¹	µm		100, 200, 300, 400, 600 or 800				
Focal Size ² (Factor to Multiply with Fiber Core Diameter)	µm	1.5 x ±50µm	4.7 x ±50µm	3.1 x ±50µm	2.3 x ±50µm	1.0 x ±50µm	
Pyrometer							
Measuring Wavelength	nm		1800 - 2100				
Temperature Range	°C		190 - 700				
Sampling Rate (max.)	kHz		10				
CCD Camera							
Image Sensor	"		1/3				
Image Sensor Area	mm ²		4.8 x 3.6				
Horizontal Frequency	kHz		15.625				
Vertical Frequency	Hz		50				
Total Number of Pixels			537 (h) x 597 (v)				
Video Signal	Vpp		1.0 at 75 Ohm				
Signal/Noise Ratio	dB		>45				
Image Size on Monitor f100	mm ²		18 x 14 with ML f50 = 9 x 7 [mm ²]				
Gain Control			AVR automatic gain control				

Processing Head (PHFx9-CS) COMPACT Series Diode Laser System

Pyro PC

Operating Voltage	V	110-240 Single Phase
Frequency	Hz	50/60
Power Consumption	kVA	0.07
Dimensions	mm ³	176 x 483 x 520
Weight	kg	16

Overall Dimension

Length x Width x Height
Approx. 217 x 70 x 139

Weight

With SMA-905 Fiber Connector	kg	1.6
With QBH Fiber Connector	kg	1.9

Package Dimension (SMA-905)¹

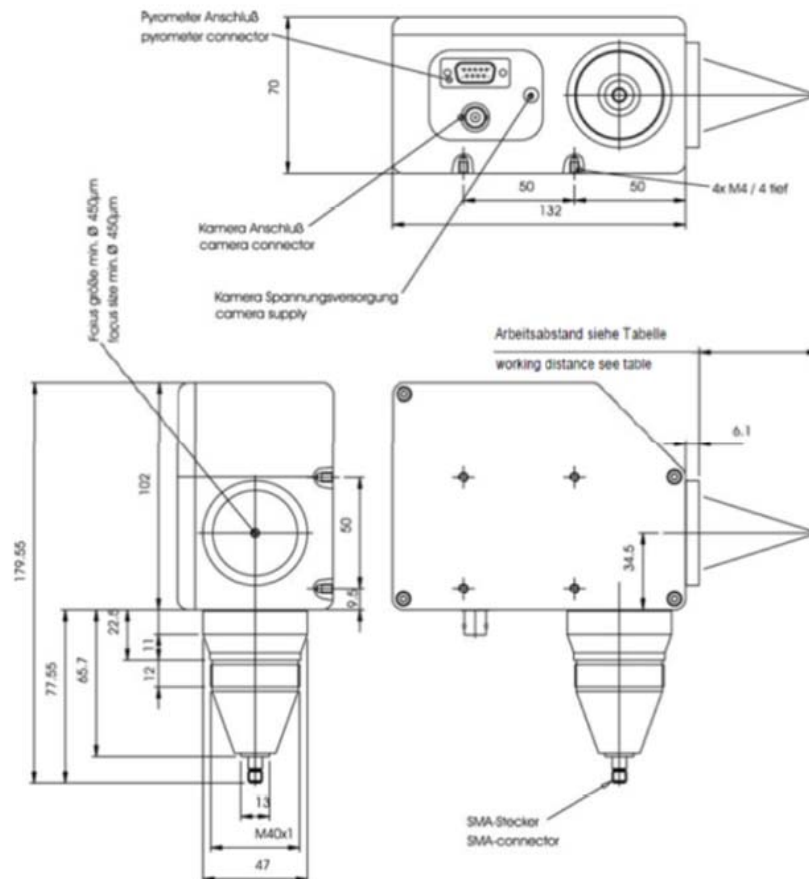

U.S. CFR Regulation

The manufacturer and subsequent sale of laser equipment is under the guidelines governed by the U.S. Center for Devices and Radiological Health (CDRH). In accordance to those guidelines, specifically Subchapter J of the Radiation Standards, 21 CFR, the diode laser is registered as a CLASS 4 laser product.

European Commission

In accordance to EN 60825, Safety of Laser Products, the diode laser is registered as a CLASS 4 laser product.

Products specifications are subject to change without notice. For handling precautions, please reference the general handling instruction manual. For additional information, please contact your local sales representative or visit our website at www.dilas-ils.com.

DILAS Industrial Laser Systems

a division of DILAS Diodenlaser GmbH
Galileo-Galilei-Straße 10
55129 Mainz
Germany

Phone: +49 (6131) 9226 400
Fax: +49 (6131) 9226 444
Email: sales@dilas-ils.com
www.DILAS-ILS.com

Processing Head (PHFx9-CS) COMPACT Series Diode Laser System

Package Dimension (QBH)¹

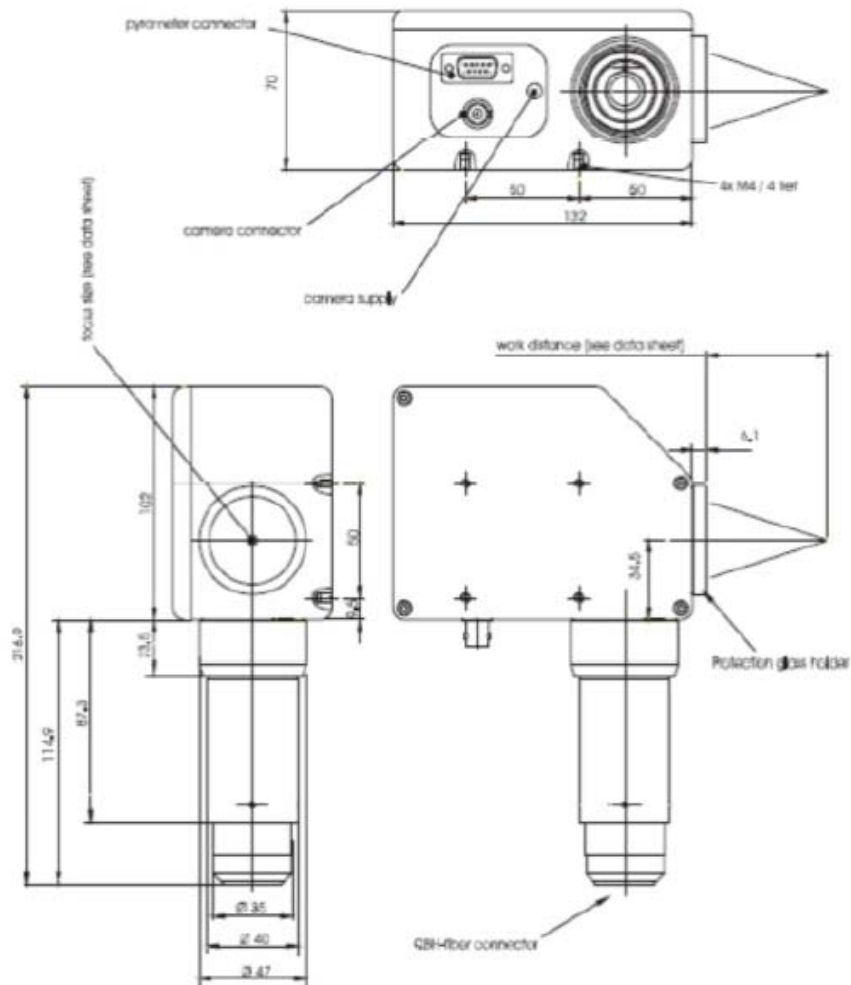

Package Includes

Processing Head PHFx9-CS, Industrial-PC with build-in-Controller Card for Pyrometer, software package Lascon Server/Lascon Process Manager, Monitor, keyboard and mouse.

¹Consult DILAS Industrial Laser Systems for other available options.

²Focal dimensions of diode lasers can deviate in practice depending on measuring method by $\pm 10\%$.

³For standard focal length $f=100$.



U.S. CFR Regulation

The manufacturer and subsequent sale of laser equipment is under the guidelines governed by the U.S. Center for Devices and Radiological Health (CDRH). In accordance to those guidelines, specifically Subchapter J of the Radiation Standards, 21 CFR, the diode laser is registered as a CLASS 4 laser product.

European Commission

In accordance to EN 60825, Safety of Laser Products, the diode laser is registered as a CLASS 4 laser product.

Products specifications are subject to change without notice. For handling precautions, please reference the general handling instruction manual. For additional information, please contact your local sales representative or visit our website at www.dilas-ils.com.

DILAS Industrial Laser Systems

a division of DILAS Diodenlaser GmbH
Galileo-Galilei-Straße 10
55129 Mainz
Germany

Phone: +49 (6131) 9226 400

Fax: +49 (6131) 9226 444

Email: sales@dilas-ils.com
www.DILAS-ILS.com