

# Galvo Scanner with Integrated Pyrometer (DL.S20P)

## Features

The galvo scanner DL.S20P is a fast 2-axis beam deflection unit needed for quasi-simultaneous welding of polymers with closed loop temperature control of the process. It allows fast positing of the laser focus in the working field without additional mechanical axes. The on-axis single color pyrometer provides non-contact temperature measurement of the welding zone. Used with the COMPACT Series, the unit is equipped with a fiber connector, collimating unit and supporting software which provides complete process data documentation for quality control.

## Package

Equipped with mounting plate and fiber-coupled collimating with an on-axis single color pyrometer, color-corrected F-Theta optics, supporting software and power supply (galvo driver, galvo PC with VLM software, pyrometer PC with LASCON software, monitor, keyboard and mouse).



## Device Specification

Optical	Units	DL.S20P
Wavelength	nm	980 (1800 - 2100 pyrometer signal)
Optical Output Power	W	<300
Focal Length <sup>1</sup>	mm	262
Working Field	mm <sup>2</sup>	140 x 140
Spot Size (200 µm)	mm	1.4
Spot Size (400 µm)	mm	2.8

Fiber Parameters		
Fiber Connector Type <sup>2</sup>		SMA, RQB or QBH
Numerical Aperture	NA	0.22

Thermal Parameters		
Ambient Temperature	°C	+15 to +35 (non condensing)
Storage Temperature	°C	5 to +50

Mechanical of Galvo Scanner		
Dimensions <sup>3</sup>	mm <sup>3</sup>	420 x 350 x 145
Weight <sup>3</sup>	kg	~13.4

Galvo Driver		
Operating Voltage	V	200-240 Single Phase
Frequency	Hz	50/60
Power Consumption	kVA	0.020
Dimensions	mm <sup>3</sup>	44 x 483 x 265
Weight	kg	2.9

Galvo PC		
Operating Voltage	V	110-240 Single Phase
Frequency	Hz	50/60
Power Consumption	kVA	0.07
Dimensions	mm <sup>3</sup>	176 x 483 x 520
Weight	kg	16

# Galvo Scanner with Integrated Pyrometer (DL.S20P)

## Pyro PC

Operating Voltage	V	110-240 Single Phase
Frequency	Hz	50/60
Power Consumption	kVA	0.07
Dimensions	mm <sup>3</sup>	176 x 483 x 250
Weight	kg	16

## Pyrometer

Measuring Wavelength	nm	1800 - 2100
Temperature Range	°C	190 - 700
Sampling Rate (max.)	KHz	10

<sup>1</sup>Consult DILAS Industrial Laser Systems for other available options.

<sup>2</sup>Based on the COMPACT Series output power.

<sup>3</sup>DL.S20P with a mounting plate, QBH collimating unit and F-Theta optics.

## Package Dimensions

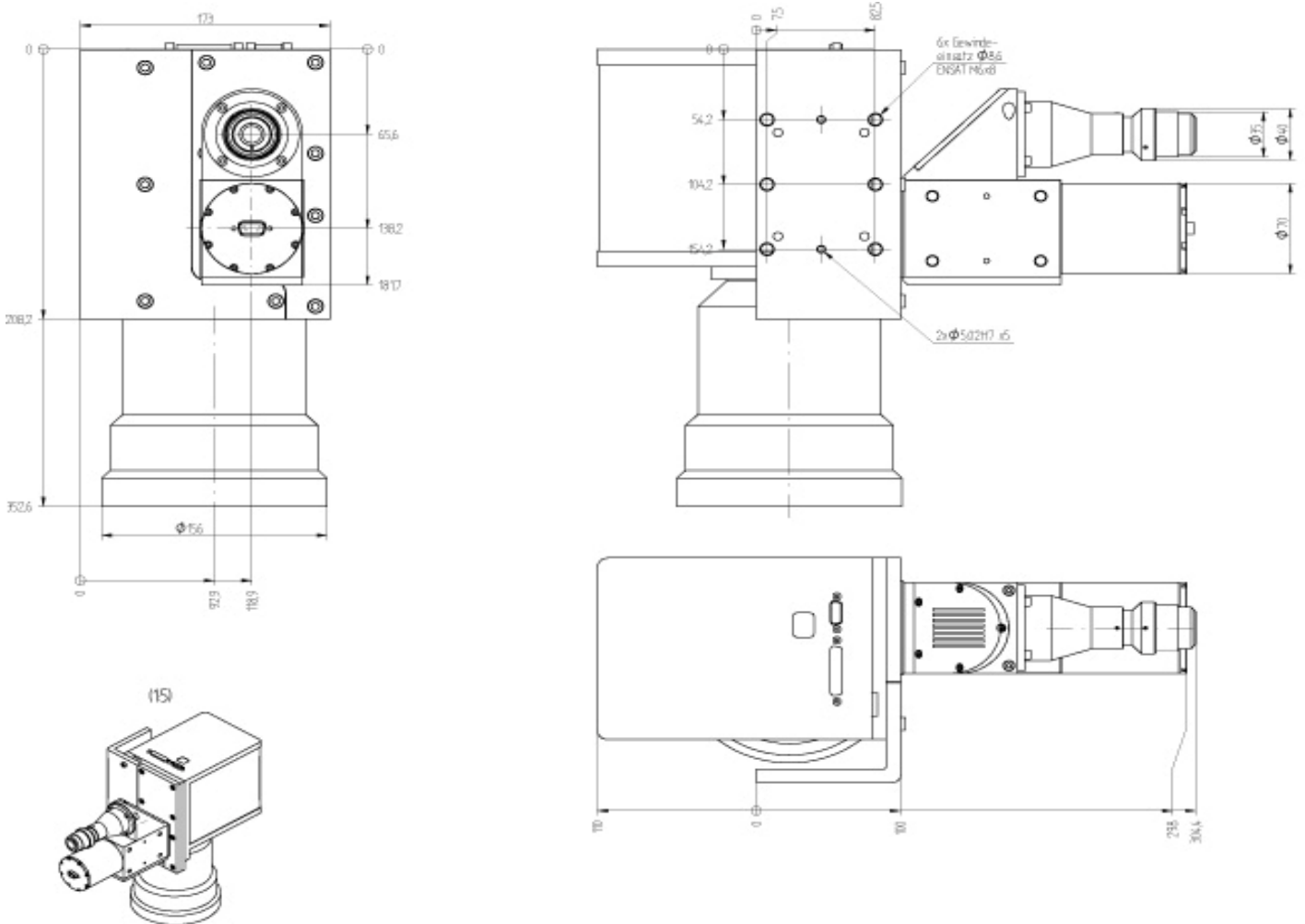

### U.S. CFR Regulation

The manufacturer and subsequent sale of laser equipment is under the guidelines governed by the U.S. Center for Devices and Radiological Health (CDRH). In accordance to those guidelines, specifically Subchapter J of the Radiation Standards, 21 CFR, the diode laser is registered as a CLASS 4 laser product.

### European Commission

In accordance to EN 60825, Safety of Laser Products, the diode laser is registered as a CLASS 4 laser product.

Products specifications are subject to change without notice. For handling precautions, please reference the general handling instruction manual. For additional information, please contact your local sales representative or visit our website at [www.dilas-ils.com](http://www.dilas-ils.com).

**DILAS Industrial Laser Systems**  
a division of DILAS Diodenlaser GmbH  
Galileo-Galilei-Straße 10  
55129 Mainz  
Germany

Phone: +49 (6131) 9226 400  
Fax: +49 (6131) 9226 444  
Email: [sales@dilas-ils.com](mailto:sales@dilas-ils.com)  
[www.DILAS-ILS.com](http://www.DILAS-ILS.com)